

Revision and History

Part No.: SCM06-100065471V

Product code: TBD

Page: 1/4

Rev.	Date	Revision Description	Checked	Approved
A1	Nov/12/2019	Initial release.	Louise Liu	Cason Chen

CHIKARA
CHIKARA
CHIKARA

Spec Sheet

Part No.: SCM06-100065471V

Product code: TBD

Page: 2/4

Features

- Common mode filters
- Storage temperature range:-40°C to +85°C
- Operating temperature range:-40°C to +125°C
(including coil's self-temperature rise)
- Moisture sensitivity level:1
- Packaging:800pcs. Per 13-inch reel
- RoHS&Halogen-free compliance

Mechanical Dimension(Unit:mm)

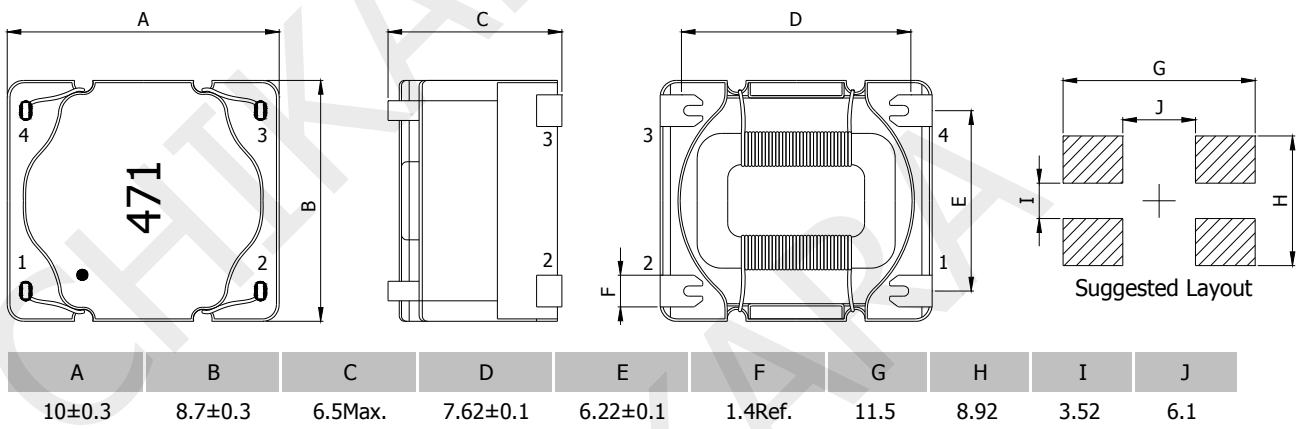

Electrical Schematic

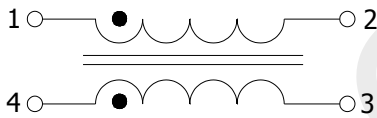

Part Number Description

SCM06 - 100065 471 V

①

②

③

④

- ① Type
- ② Dimensions
- ③ Inductance value
- ④ Tolerance code

Electrical Characteristic

Inductance (uH)	Max.Impedance (Ω)Typ.	Rated Current (A)Max.	Rated Voltage (V)Max.	Hi-Pot (Coil - Coil)	DCR (Ω)Max.
470±40%	1750	1.6	80	AC1000V 3mA/3S	0.065

- All test data referenced to 25°C ambient.
- Test frequency and voltage:100KHz,0.1Vrms.
- Rated current:DC current when temperature of coil increased up to 45°C.

Spec Sheet

Part No.: SCM06-100065471V

Product code: TBD

Page: 3/4

Characteristic Curve(Typical value)

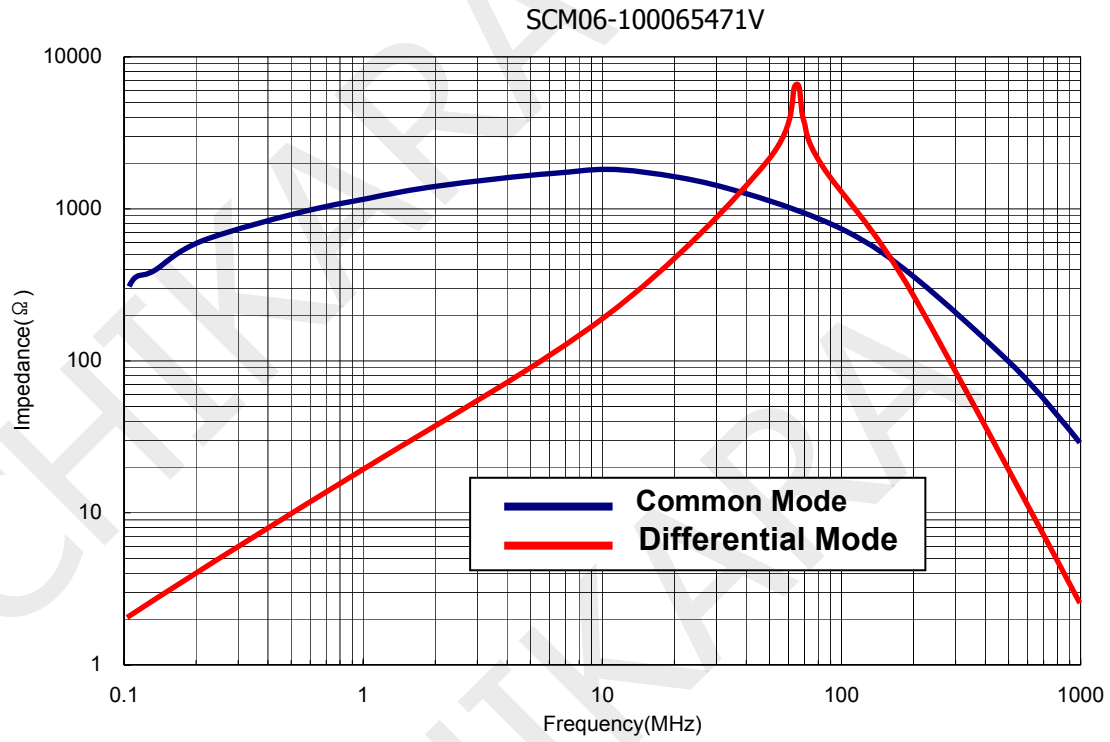

Spec Sheet

Part No.: SCM06-100065471V

Product code: TBD

Page: 4/4

Material List

No.	Materials	Description	Suppliers	UL No.
1	Core	Ferrite	Guangdong Zhaoqing Magsource Electron Co., Ltd. or Equivalent	/
2	Wire	2UEWH 180°C	PACIFIC Electric Wire&Cable(Shenzhen) Co.,Ltd. or Equivalent	E201757
3	Bobbin	LCP-E4008	Sumitomo Chemical Co.,Ltd. or Equivalent	E54705
4	Tin	Lead-free Sn99.9	Dongguan Thousand Island Metal Foil Co.,Ltd. or Equivalent	/
5	Glue	Epoxy	GUDAK Chemistry Tech(Dongguan)Co.,Ltd. or Equivalent	/